

cat. no. 510.52

Archives

CONTINUOUS LINER

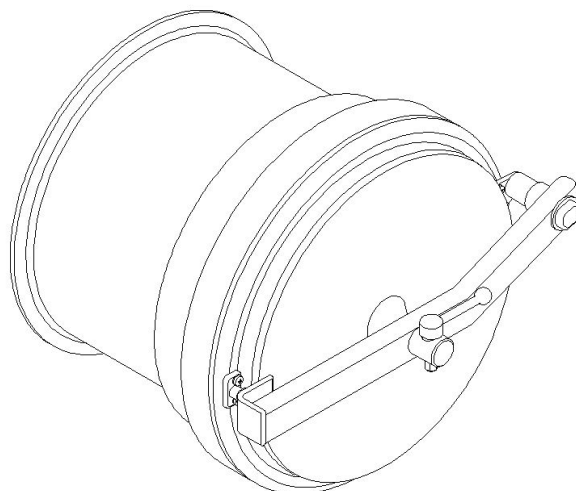
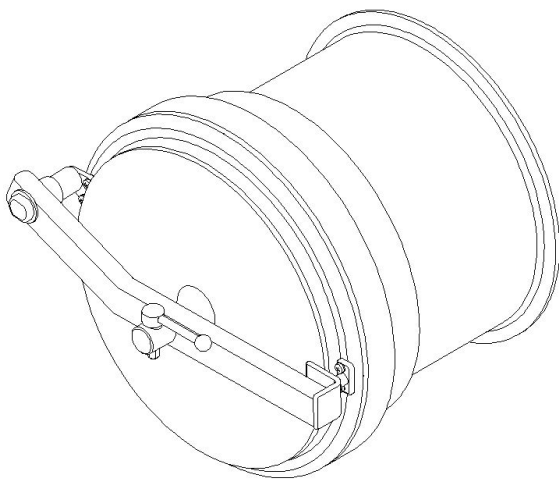
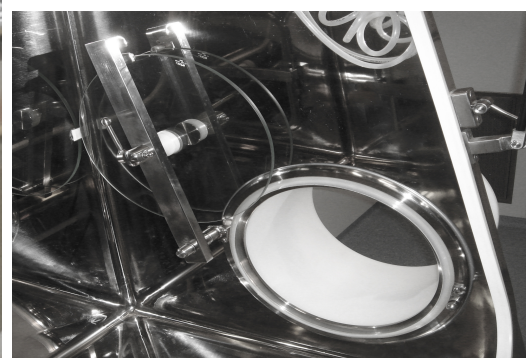
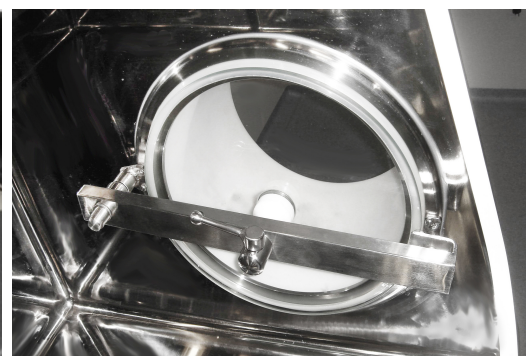

Swinging door is used to transfer material out of the chamber without contaminating the operator. There is a swinging closing mechanism inside the chamber. A tube projects outside the chamber, protected by a tubular film and used for the removal of material. A welding strip is used as optional accessory to hermetically seal the tubular film in order to avoid contamination of the operator. The door is made as right-hand side or left-hand side depending on the side of the chamber where it will be installed. The inner part of the swinging mechanism is sealed using a static seal. The door is made using AISI316L, safety glass, POM-C FDA CRF.177.2470 and FDA CRF.177.2600 compliant silicone seal.

TECHNICAL DATA

Door type designation

Type designation of doors

Selecting dimensional range

Inside diameter 170 mm

Inside diameter 300 mm

In this category, you can select the inner diameter.

Selecting opening mode

Left side of body

Right side of body

In this category, you can select the side on which the swinging door will be mounted.

Selecting welding strip

Welding strip not required

Welding strip required

In this category, you can select the delivery of a welding strip for the dimensional range concerned - i.e. whether it will be required or not.

MORE INFORMATION, PHOTOS

